

Gravity Separator GA 210



Grains or particles of almost identical size are fed continuously on the separating deck surface of the separator, providing a uniform bed of material over the deck surface.

The deck is fluidised by a completely uniform pressurised air system stratifying the light material to the top of the product bed and allowing the heavy material to contact the deck surface. The deck is inclined from side to side and inlet end to discharge end at adjustable angles.

The deck itself is powered by a fully balanced eccentric drive which moves the deck at low amplitude and high frequency up hill. The heavy material contacting a specially designed square wire deck surface moves up hill, while the light material fluidised by the air system moves down hill due to gravitational pull. A typically separation pattern is depicted below.

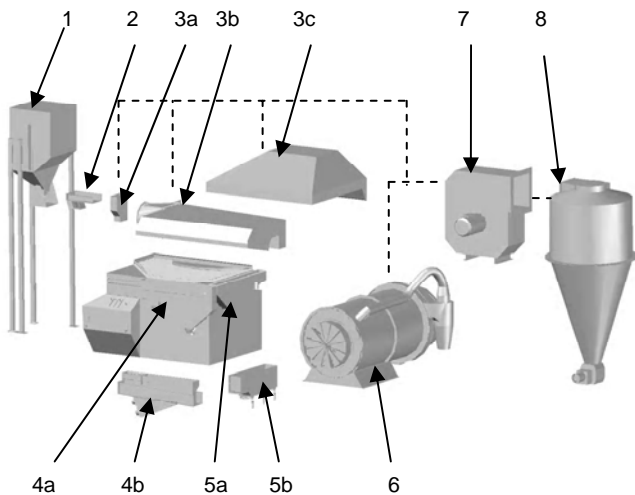

1. **Intake pre-storage hopper**
for intake adjustment between feeder-elevator and electro-magnetic feeder SP 18 incl. 3 level indicator switches.
Delivery with or without supporting legs
2. **Electro-magnetic feeder type SP 18**
for the trouble-free, continuous feeding of the machines
- 3a. **Intake dust-aspiration hopper**
light dust and fines removal from the product to be cleaned. Connection to central dust exhaust unit.
Air requirement: 12 m³/min, 300 Pa
- 3b. **Partial dust hood**
In case of heavy dust formation, for the removal of dust from the incoming material and the light produce area. Connection to central dust exhaust or individual cyclone and ventilator. Incl. Intake dust-aspiration hopper and frame.
Air requirement: 210 m³/min, 300 Pa
- 3c. **Full dust hood**
complete closed; suction over the whole table area.
With frame.
Air requirement: 550 m³/min, 300 Pa

- 4a. **Discharge hopper for heavy product**
- 4b. **Vibrating discharge trough for heavy product with stone trap.**
- 5a. **Vibrating discharge trough for light product**
- 5b. **Bagging-off type hopper**
for design with BASE STRUCTURE (required, if BAGGING-OFF type hoppers instead of discharge hopper will be supplied)
6. **Cyclofan**
7. **Exhaust fan**
With motor, without support structure
8. **Dust separating cyclone with rotary valve**

Technical data

Capacity		
Corn, Wheat, Soybeans		10,0 t/h
Peas, Beans		7,5 t/h
Clover		4,0 t/h
Coffee (green)		6,7 t/h
Screen area		3,6 m ²
Motors: (standard)		
Fan drive		11,0 kW
Reciprocating drive		1,1 kW
Air volume:		
Air requirements		470 m ³ /min
Dimensions		
Length		3288 mm
Width		1905 mm
Height		1442 mm
Total weight of separator		
Net		1830 kg
Dynamic loading at 7-12 Hz:		
PH=+/- 450 N	PV=+/- 160 N	(10N = 1 kg)

Technical data can vary for certain of the above due to continued development, or a different machine composition.